



**Armoire à vin.**

**Wine Preservation Technology**

## **USER MANUAL**

**V30SG**

**V40SG**

**V50SG**

**V30SGMe**

**V30SG"e"/AL-V30SG"e"**

**V40SG"e"/AL-V40SG"e"**

**V50SG"e"**

**V26SG"e"**

**V30SG"2e"/AL-V30SG"2e"**

**V40SG"2e"/AL-V40SG"2e"**

**V40SD"2e"**

**V50SG"2e"**

**V40DG"2e"/AL-V40DG"2e"**

**V50DG"2e"**

## WARNING

*The information in this document is subject to modification without any prior notice.*

**VINTEC** offers no guarantee for our wine cellar if it is being used for any purpose other than that for which it was specifically designed. **VINTEC** cannot be held responsible for any error in this manual. **VINTEC** is not responsible or liable for any spoilage or damage to wines or any other contents incidental or consequential to possible defects of the wine cellar. Warranty applies to the wine cellar only and not to the content of the wine cellar.

This appliance is not intended for use by persons (including children) with reduced physical, sensory or mental capabilities, or lack of experience and knowledge, unless they have been given supervision or instruction concerning use of the appliance by a person responsible for their safety.

Children should be supervised to ensure that they do not play with the appliance.

### **R600A WARNINGS**

The following models use small quantity of R600A (iso-butane) flammable refrigerant in their sealed system as follow:

<b>AL-V30SG”e”</b>	<b>– 30g</b>	<b>AL-V30SG”2e”</b>	<b>– 30g</b>
<b>AL-V40SG”e”</b>	<b>– 35g</b>	<b>AL-V40SG”2e”</b>	<b>– 35g</b>
<b>AL-V40DG”2e”</b>	<b>– 45g</b>	<b>V26SG “e”</b>	<b>– 30g</b>
<b>V40SD”2e”</b>	<b>– 35g</b>		

For your safety observe the following recommendations.

- This appliance contains a small quantity of R600A refrigerant which is environmentally friendly, but flammable. It does not damage the ozone layer, nor does it increase the greenhouse effect.
- During transportation and installation, ensure that the tubing of the refrigerant circuit is not damaged.
- Avoid using or manipulating sharp objects nearby the appliances.
- Leaking refrigerant can ignite and may damage the eyes.
- In the event any damage does occur, avoid exposure to open fires and any device which creates a spark. Disconnect the appliance from the mains power.
- Thoroughly ventilate the room in which the appliance is located for several minutes.
- Notify Customer Service for necessary action and advice.

- The room for installing the appliance must be at least 1 cubic metre per 8 grams of refrigerant. The refrigerant quantity contained in this appliance is listed above in grams; it is also noted on the Rating Plate of the appliance.

**It is hazardous for anyone other than an Authorised Service Person to carry out servicing or repairs to this appliance. In Queensland the authorized person must hold a Gas Work Authorisation for hydrocarbon refrigerants, before carrying out servicing or repairs which involve the removal of covers.**

- WARNING: Keep ventilation openings, in the appliance enclosure or in the built-in structure, clear of obstruction.
- WARNING: Do not use mechanical devices or other means to accelerate the defrosting process, other than those recommended by the manufacturer.
- WARNING: Do not damage the refrigerant circuit.
- WARNING: Do not use electrical appliances inside the food storage compartments of the appliance, unless they are of the type recommended by the manufacturer.

The environment and personal safety must be considered when disposing of this appliance. Please ensure the appliance is taken to a recycle center for safe recycling. DO NOT dispose of the appliance in land fill as the insulation and refrigerant gas contained in these appliances are flammable.

**Allow 24 hours before switching on the wine cellar. During this time we recommend that you leave the door open to clear any residual odors.**

## **BEFORE LOADING & PLUGGING IN THE WINE CELLAR**

***Important: All models without front venting (air opening) are strictly for free standing only. ( see technical chart)***

### **Recommendations:**

The location you have selected for your wine cellar should:

- be unencumbered and well ventilated;
- be well away from any heat source and direct sunlight;
- not be too damp (laundry, pantry, bathroom etc.);
- have a flat floor,
- have a standard and reliable electricity supply (standard socket to country standards, linked to the ground), it is NOT recommended to use a multi-socket or extension lead.
- have a surge protector fitted to the electrical outlet
- away from the microwave.

Certain microwave ovens do not have wave interference shield. When placed within a 1 meter vicinity of the wine cabinet, they may affect the operation of the wine cabinet.

**Notes:**

- V30 models are for free standing ONLY:
- V40 & V26 models are built-in type as per the drawings thereafter;
- V50 models are partially built-in, MUST allow 1cm to, side & back clearance.

The wine cellar should be placed where the ambient temperature is between 5°C to 35°C. If the ambient temperature is above or below this range, the performance of the unit may be affected. Placing your unit in extreme cold or hot conditions may cause interior temperatures to fluctuate. The ideal range of temperature may not be reached. (See Climate Class at the end of this manual)

**Grounding instructions**

The wine cellar must be grounded in case of an electrical short circuit. Grounding reduces the risk of electrical shock. The wine cellar is equipped with a power cord having a grounding wire and plug. The wine cellar plug must be plugged into a properly affixed and grounded electrical outlet.

**Note:** *In locations where there is frequent lightning, it is advisable to use surge protectors.*

Improper use of the grounding plug can result in the risk of electric shock. Consult a qualified electrician or service person if the grounding instructions are not completely understood.

If the supply cord is damaged, it must be replaced by a qualified person in order to avoid electrical hazard.

**INSTALLING YOUR WINE CELLAR**

Unpack and remove all of the protection and adhesive strips from the packaging around and inside the wine cellar.

The wine cellar must be positioned such that the plug is accessible. Release the power cord. Move your wine cellar to its final location. The wine cellar should be installed in a suitable place where the compressor will not be subject to physical contact.

**Leveling your wine cellar:** Wine cellar must be leveled BEFORE loading your wines. Your Vintec wine cellar is equipped with 4 adjustable feet to facilitate easy leveling. VINTEC recommends that you tighten the back feet to the maximum and adjust the front feet to create a level.

### Fixing the Back spacer:

Compressor run appliances require proper ventilation for proper and longer usage. Your Vintec wine cellar is supplied with a back spacer. Affixed the back spacer at the back of the cellar for air circulation and heat evacuation.

### INSTALLATION OF BACK SPACER

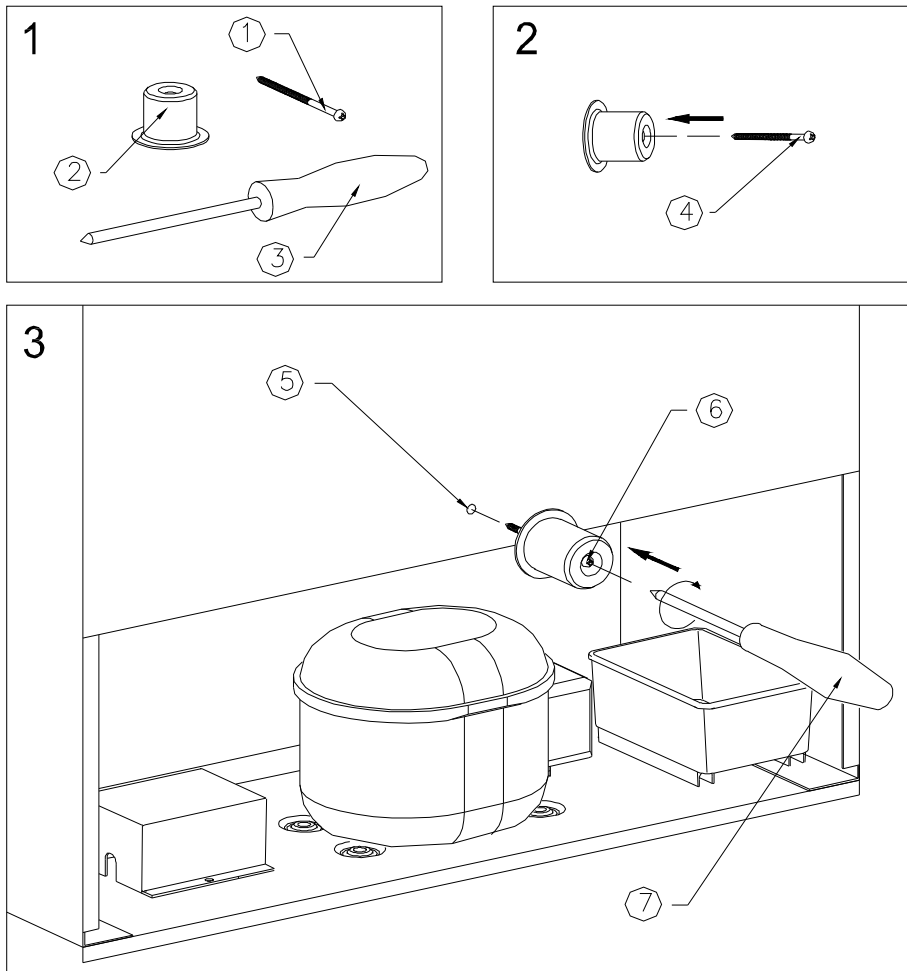

**IMPORTANT - THIS SPACER MUST BE ATTACHED TO THE UNIT BEFORE THE INSTALLATION, FOR VENTILATION PURPOSE. FAILURE TO DO SO VOIDS THE WARRANTY**

**INSTALLATION INSTRUCTIONS FOR BUILT IN WINE CELLARS:  
(UNDERBENCH OR IN COLUM) *FRONT VENTING WINE CELLARS ONLY.***



**V30 models are free standing only. Any built in voids the warranty**

1. Vintec “Built in” wine cellars are front venting but are not designed to be fully integrated behind a joinery door.
2. The Vintec “Built in” wine cellar require 10mm clearance on both sides and top, 30mm clearance at the rear (Back spacer is provided),to facilitate installation, removal, servicing and ventilation.
3. Vintec “Built in” wine cellars draw air from the rear and expels through the metal grid under the door at the front. If a kick board is to be placed in front of the wine cellar’s grid another one must be fitted into the kick board with a minimum air flow allowance of 150cm<sup>2</sup>.
4. Vintec “Built in” wine cellars have a power switch located on the control panel so power point location is not critical.
5. This wine cellar requires a standard 240 volt/10 amp power point. (Or other according to various countries specifications)
6. The power cord is 1.9m in length and is fixed on the right side at the back when looking from front of cabinet.
7. As with most appliances of today, this wine cellar has sensitive electronic components which are susceptible to damage through lightning and electricity supply faults. It is therefore advised to use a power surge protector to avoid problems of this nature.

**8 Air vent within the joinery must be provided for Vintec built in wine cellars (front venting)**

In Hot climate zone, air vents, with a minimum ventilation size of 200mm x 40mm MUST be cut out at the rear at the top of the back partitioning or at the top of either side of the partitioning, giving cool fresh air full access to flow into the 30mm gap located at the rear of the cabinet.

The air vent must not be installed on the same side of other appliances producing heat such as ovens or to an area that is sealed or with out access to fresh cool air. Failing to comply with the above specifications could result in WARRANTY void.

**INSTALLATION DRAWINGS FOR BUILT IN WINE CELLARS: (UNDERBENCH OR IN COLUMN) *FRONT VENTING WINE CELLARS ONLY.***

Suitable points for ventilation grid.  
Note: only one vent is required

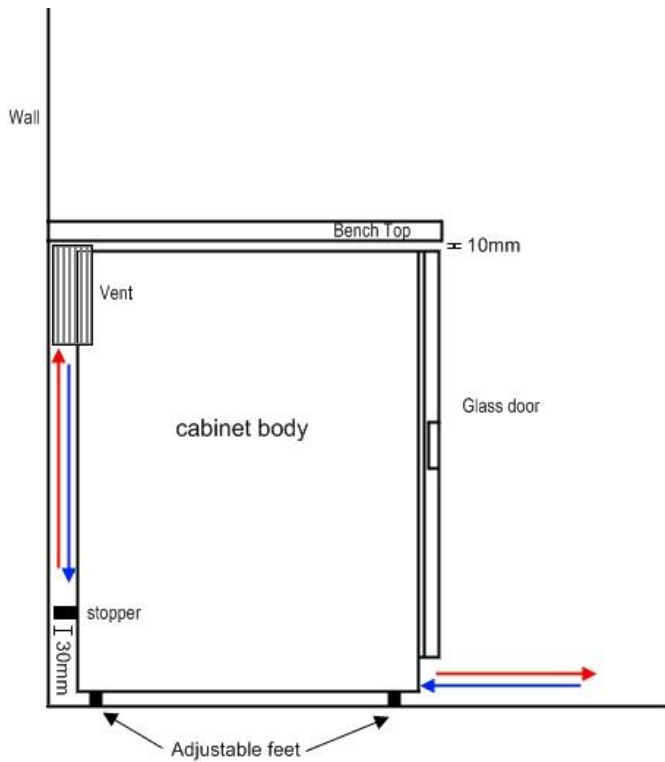
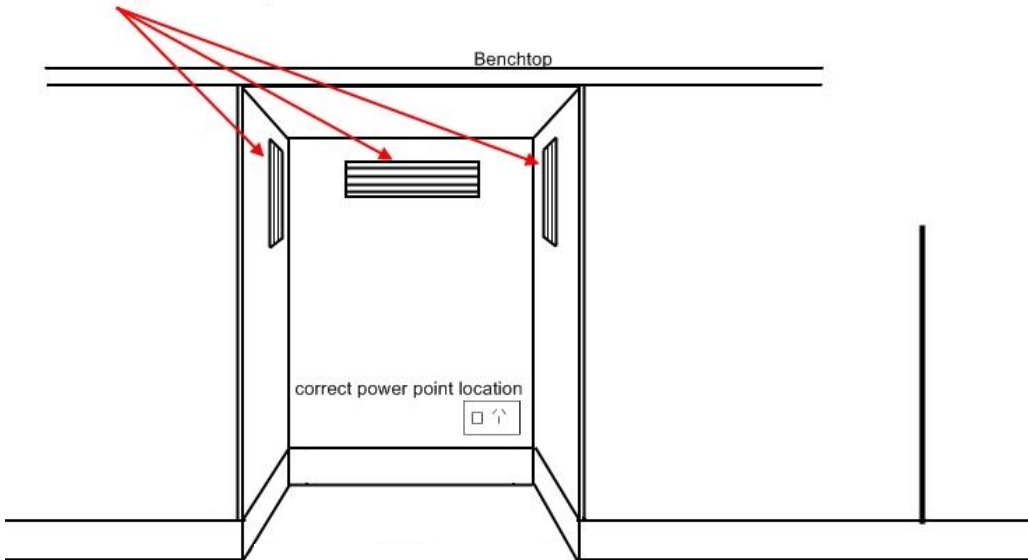

## Dimensional drawings:

### V26's

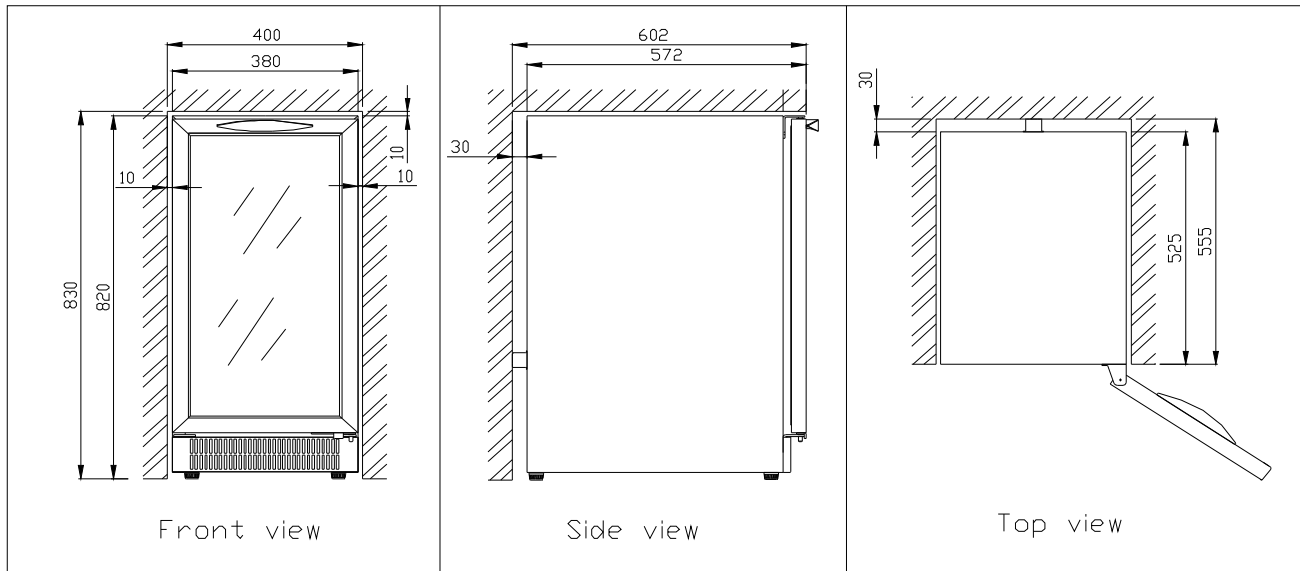

### V40's (30mm recess plinth)

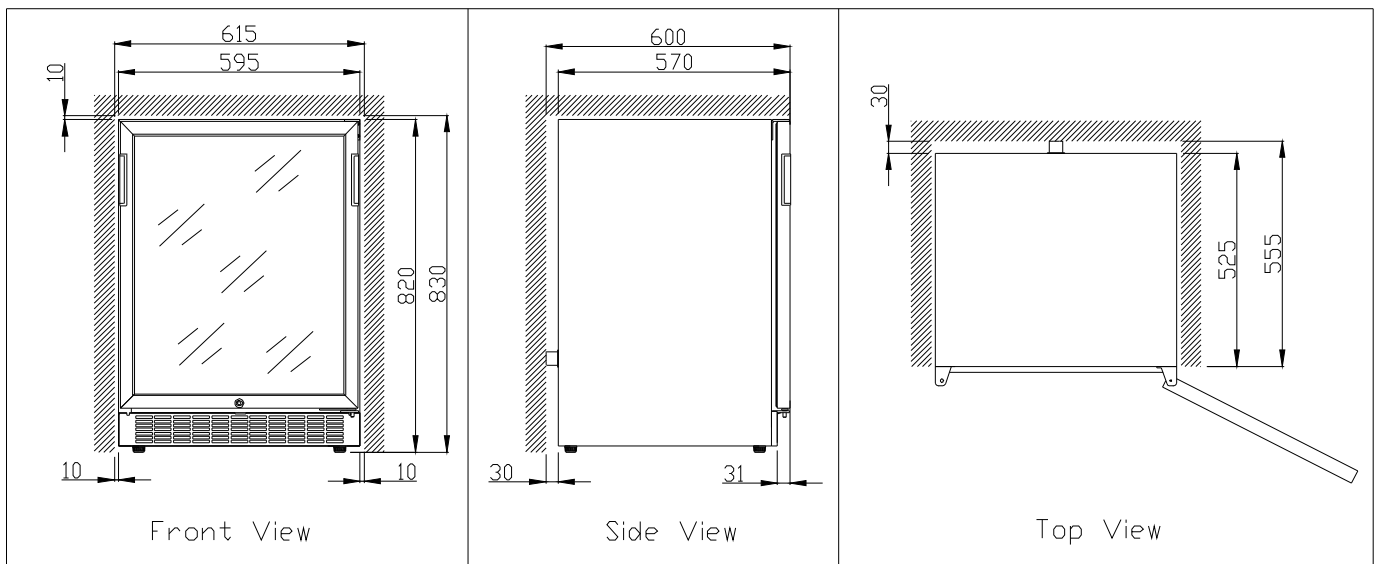



**V40's (85mm recess plinth)**

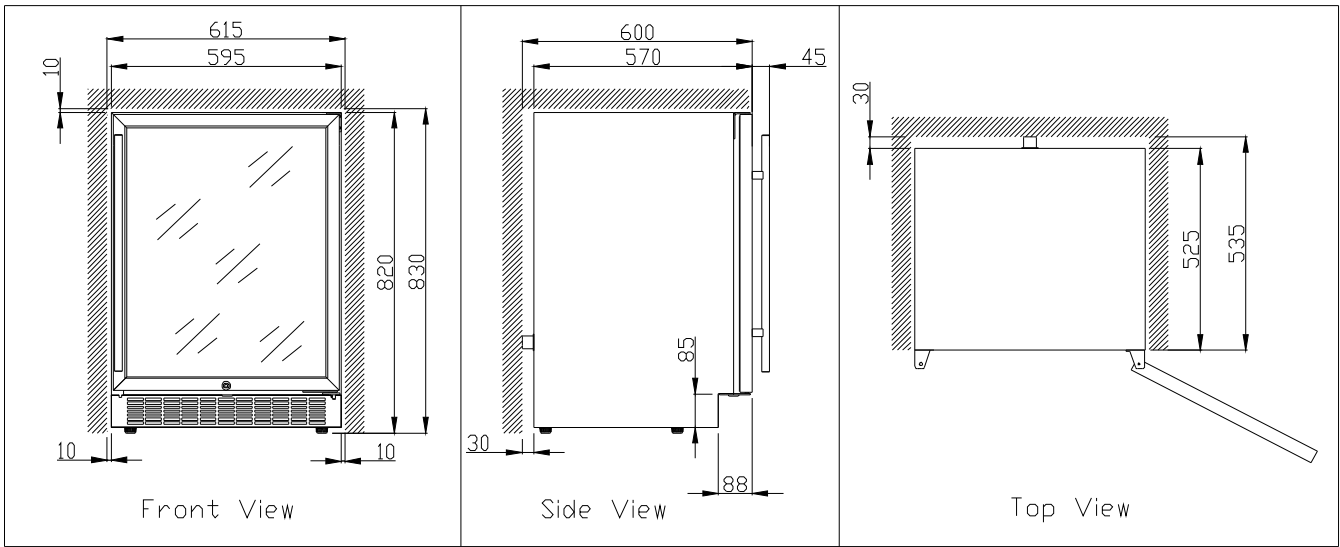

**V 50's Dimensional drawings:**

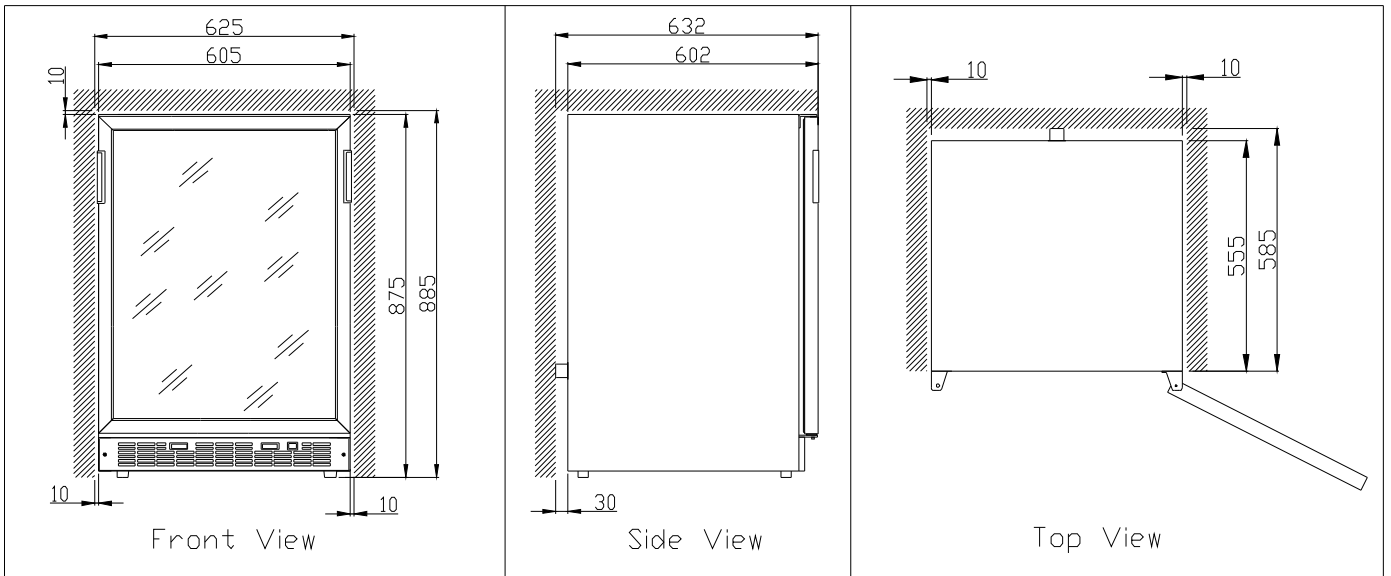

## TURNING ON YOUR WINE CELLAR

Plug in and switch on the cellar by pressing on the power button **for a few seconds**.

When you use the wine cellar for the first time (or restart the wine cellar after having it shut off for a long time), there will be a few degrees, variance between the temperature you have selected and the one indicated on the LED readout. This is normal and it is due to the length of the activation time. Once the wine cellar is running for a few hours everything will stabilize.

***Important: If the unit is unplugged, power is lost, or turned off, wait 3 to 5 minutes before restarting the unit. The wine cellar will not start if you attempt to restart before this time delay.***

### Operating Noises

To reach the desired temperature settings, VINTEC wine cellars, like all wine cellars operating with compressors and fans, may produce the following types of noises. These noises are normal and occur as follows:

- Gurgling sound, caused by the refrigerant flowing through the appliance's coils,
- Cracking/popping sounds, resulting from the contraction and expansion of the refrigerant gas to produce cold,
- Fan operating sound, to circulate the air within the wine cellar.

*An individual's perception of noise is directly linked to the environment in which the wine cellar is located, as well the specific type of models. VINTEC wine cellars are in line with international standards for such appliance. VINTEC will always do its utmost to satisfy its customers but will not retake possession of the goods due to complaints based on normal operating noise occurrences.*

## LOADING YOUR WINE CELLAR

You may load your wine bottles in single or double rows while taking note of the following: if you do not have enough bottles to fill your wine cellar, it is better to distribute the load throughout the wine cellar so as to avoid "all on top" or "all below" type loads.

- Do remove or relocate adjustable wooden shelves to accommodate larger type of bottles or increase the capacity of the cellar by stacking the bottles up when necessary. (See removing shelves)
- Keep smalls gap between the walls and the bottles to allow air circulation. Like an underground cellar air circulation is important to prevent mould and for a better homogeneous temperature within the cellar.



- Do not over load your wine cellar to facilitate air circulation
- Do not stack more than 1.5 rows of standard 0.75L bottles per shelves to facilitate air circulation
- Avoid obstructing the internal fans (located inside on the back panel of the wine cellar).
- Do not try to slide the shelves outwards beyond the fixed position to prevent the bottles from falling.
- Do not pull out more than one loaded shelf at a time as this may cause the wine cellar to tilt forward.
- Do not cover the wooden shelves with alloy foil or other materials, as it will obstruct air circulation.
- Do not move your wine cellar while it is loaded with wines. This might distort the body of the wine cellar and cause back injury.

## **TYPES OF REGULATION**

Please note that depending on the loading and settings chosen it takes 24hours for the wine cellar to see the temperature stabilizing.

During this time LED seems to move erratically in particular for 2e models. It is a normal process. This process occurs whenever the setting is modified and/or whenever a large amount of bottles are added to the cellar.

### **Single temperature Maturing/Storage wine cellars:**

V30SG, V40SG, V50SG: standard regulation

V30SGMe: easy electronic regulation, digital display

V30SG"e", V40SG"e", V50SG"e", V26SG"e": electronic regulation, digital display.

Designed to store and mature all wines: red, white and sparkling. These wine cellars reproduce the ideal conditions for **wine storage**, at a constant recommended temperature of 12°C. They can also be set to provide ideal serving temperature for full enjoyment of the wine's qualities. Unless stated by the wine maker on the bottle, **VINTEC** recommends 7°C for your champagne, 12°C for whites and 18°C for reds. (Refer to "Wine Service Temperature" recommendation chart)

### **Two Compartment single temperature wine cellars (2-in-1 Wine Cellars):**

V40DG"2e", V50DG"2e" : electronic regulation digital display

DG models are made of two independent compartments regulated independently as 2 single zone wine cellars. Like the e models, each compartment are adjustable from 5°C to 18°C. Ideal for storage or "mise en temperature" (The right temperature for optimum enjoyment)

## Two Temperature Serving Wine Cellars:

V30SG"2e", V40SG"2e", V50SG"2e" , V40SD"2e": electronic regulation digital display

Designed to store wines at the correct temperature for best enjoyment. The upper chamber can hold 12, 14 or 16 bottles, depending on the models, at a temperature of 5°C to 10°C dedicated mainly to **white, sparkling wines and champagnes**. The lower chamber accommodates 20, 30 or 34 bottles, depending on the models, mainly for **red wines**, which could be stored either at room temperature (18°C-20°C) for consumption or at 12°C for a longer time of storage.

## TEMPERATURE SETTINGS

*Important: The LCD displays by default the actual internal air temperature.*

The temperature settings are pre-set at the factory as follows. In the event of a power interruption, all previous temperature settings are automatically erased and it will revert to the preset temperature settings.

### Factory preset chart

Model	Setting	Temperature
V30 / V50 SG	Normal	10°C -14°C
V30SGMe	12	12°C (+/- 2.5°C)
V30 / V40/ V50 /V26 SG "e"	12	12°C (+/- 2.5°C)
V30/ V40 / V50 SG "2e"/V40SD"2e"	Upper compartment: 6	6°C (+/- 2.5°C)
	Lower compartment: 12	12°C (+/- 2.5°C)
V40/50 DG "2e"	Left compartment: 12	12°C (+/- 2.5°C)
	Right compartment: 7	7°C (+/- 2.5°C)

*It is important to understand that there is a difference between the air temperature inside the wine cellar and the actual temperature of the wine: You will need to wait approximately 12 hours before noticing the effects of temperature adjustment due to the critical mass within a full wine cellar.*

Once the thermostat is set, it is strongly advised not to toy with it or adjust frequently. The thermostat will maintain the temperature inside the wine cellar within a +/- 2.5°C range. But the thermal inertia of the wine and the glass is such that within this temperature range, the actual temperature of the wine will only fluctuate 0.5°C to 1°C.

## Standard models:

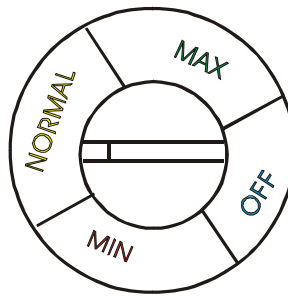

“MAX” adjustable from 5 to 9 °C

“NORMAL” adjustable from 10 to 14 °C

“MIN” adjustable from 15 to 18 °C

### To modify the pre-set temperature of standard models:

Circumrotate the knob, The knob mark is the temperature pre-set area. A clockwise turn sets a lower temperature, An anti clockwise turn sets a higher temperature.

## Electronic models:

### V30SGMe model

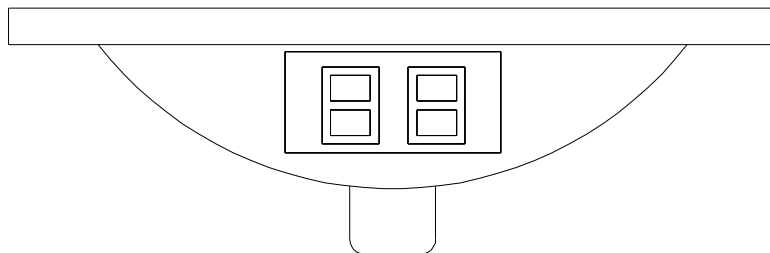

When power is connected and wine cooler is working normally the LED on the circuit board will flash, and the display will be show the actual temperature in cabinet, setting temperature range is 5-18°C.

The temperature adjustor. You press the temperature button, the temperature will be increase or reduce 1°C.

LED will flash when you setting temperature, when you stop the setting, LED will flash 5 seconds and then show the actual temperature.

### V30 “e” model

The “TEMP. SET LED, displays the set temperature

The “DISPLAY LED, displays the internal air temperature

### Control panel of V30SG e wine cellars

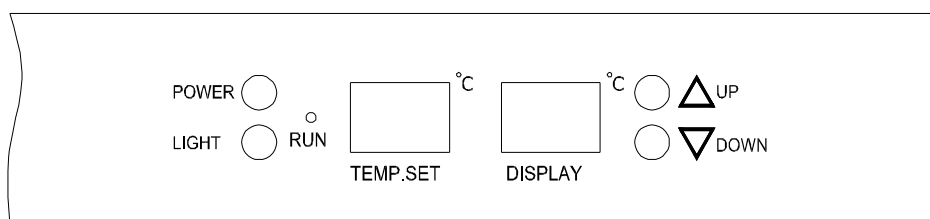

#### To modify the pre-set temperature of V30SGe models

Adjust the desired cooling temperature by pressing the UP or DOWN buttons. Each depression of the buttons will scroll through the available temperature settings in increments of 1 degree Celsius. The temperature setting can be adjusted from 3°C to 18°C or 5°C to 18°C.

#### V40SG “e”,V50SG “e”,V26SG“e” models

#### V40DG 2e. V50DG 2e models for each compartment

The “DISPLAY LED” displays the internal air temperature. The set temperature automatically appears by pressing either the UP or DOWN button

### Control panel of SG e and DG “2e “model wine cellars

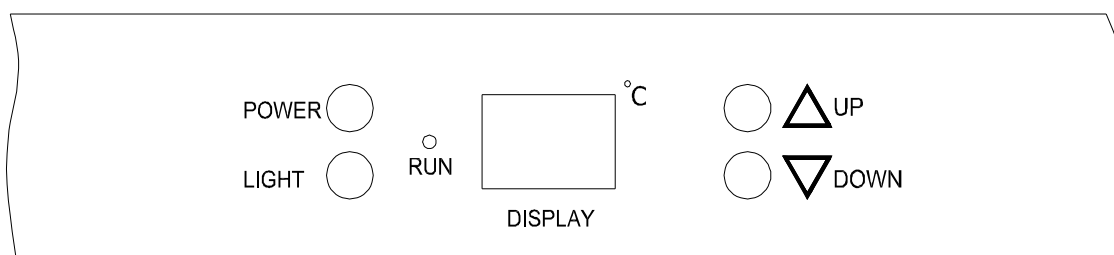

#### To modify the pre-set temperature of 40/50/26SG e and 40/50DG 2e models

Adjust the desired cooling temperature by pressing the UP or DOWN buttons. Each depression of the buttons will scroll through the available temperature settings in increments of 1 degree Celsius. The temperature setting can be adjusted from 5°C to 18°C  
To visualize the “set” temperature, press and hold the UP or DOWN buttons, the “set” temperature will temporarily “flash” in the LED display for 5 seconds.

#### SG“2e” models:

V30SG"2e", V40SG"2e", V50SG"2e", V40SD"2e",

The “UPPER CHAMBER LCD” displays the upper chamber internal air temperature

The “LOWER CHAMBER LCD” displays the lower chamber internal air temperature

To visualize the “set” temperature, press the corresponding button once, the “set” temperature will temporarily “flash” in the LED display for 5 seconds.

### Control panel of SG and SD “2e” model wine cellars

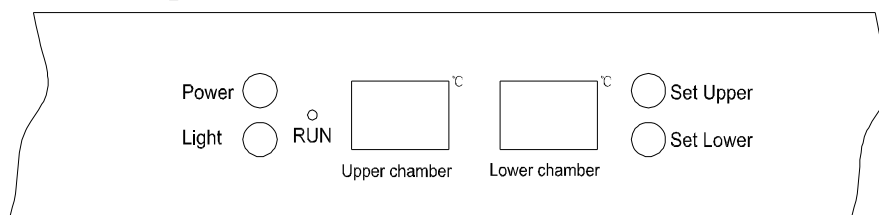

### To modify the pre-set temperature of SG and SD“2e” models

Adjust the desired cooling temperature by pressing the Set Upper or Set Lower buttons. Each depression of the buttons will scroll through the available temperature settings in increments of 1 degree Celsius. The temperature selected will flash in the LED display for approximately 5 seconds and then revert to displaying the temperature of the internal cabinet. The temperature setting can be adjusted from 5°C to 10°C in upper compartment and 10°C to 18°C in lower compartment.

### WINE SERVING TEMPERATURE CHART

All wines mature at the same temperature, which is a constant temperature set between 12°C to 14°C. The below chart is an indicative temperature chart to indicate the best temperature for drinking purposes.

Champagne NV, Sparkling, Spumante	6°C
Dry White Semillon, Sauvignon Blanc	8°C
Champagne Vintage, Dry White Chardonnay	10°C
Dry White Gewürztraminer, Riesling, Pinot grigio	10°C
Sweet White Sauternes, Barsac, Montbazillac, Ice Wine, Late Harvest Beaujolais	10°C
Sweet White Vintage: Sauternes...	13°C
White Vintage Chardonnay	14°C
Red Pinot Noir, Red Grenache, Syrah	16°C
Red Vintage Pinot Noir	16°C
Cabernet & Merlot: French, Australian, New Zealand, Chilean, Italian, Spanish, Californian, Argentinean...	18°C
Vintage Bordeaux ...	20°C
	Room temperature not exceeding 20°C

## **IMPORTANT INFORMATION ABOUT TEMPERATURE**

Your VINTEC wine cellar has been designed to guarantee optimum conditions for storing and/or serving your wines.

Fine wines require long and gentle developments and need specific conditions in which to reach their full potential.

All wines mature at the same temperature, which is a constant temperature set between 12°C to 14°C. Only the temperature of “dégustation” (wine appreciation) varies according to the type of wines (see “Wine Serving Temperature Chart” above). This being said and as it is for natural cellars used by wine producers for long period of storage, it is not the exact temperature that is important, but its consistency. In other words, as long as the temperature of your wine cellar is constant (between 12°C to 14°C) your wines will be stored in perfect conditions.

Not all wines will improve over the years. Some should be consumed at an early stage (2 to 3 years) while others have tremendous ageing capability (50 and over). All wines have a peak in maturity. Do check with your wine merchant to get the relevant information.

## **DEFROSTING/CONDENSATION/ HYGROMETRY/ VENTILATION**

Your wine cellar is designed with “Auto-cycle” defrost system. During “Off-cycle” the refrigerated surfaces of the wine cellar defrost automatically. Defrost water from the wine cellar storage compartment drains automatically and part of it goes into a drainage container, which is located at the back of the wine cellar next to the compressor. The heat is transferred from the compressor and evaporates any condensation that has collected in the pan. Part of the remaining water is collected within the wine cellar for humidity purposes.

This system enables the creation of the correct humidity level inside your wine cellar required by the natural cork to maintain a long lasting seal.

**Notes:** *The water collected by condensation, is therefore recycled. Under extremely dry environmental conditions, you may have to add some water into the water container provided with your wine cellar.*

All units are equipped with a double glazed glass door that has a third internal acrylic layer to minimize condensation on the glass door.

The wine cellar is not totally sealed; fresh air admission is permitted through the drainpipe. Air is circulated through the cellar by means of a fan/fans and the hollow shelves.



**Notes:** *During the refrigerating cycle, heat is given off and disperse through the external surfaces of the wine cellar. Avoid touching the surfaces during those cycles.*

## **ADJUSTABLE WOODEN SHELVES**

### **Adjusting/removing the shelves**

For easy access to the storage content, you must pull the shelves approximately 1/3 of its depth out of the rail compartment. These wine cabinets, however, are designed with a notch on each side of the shelf tracks to prevent bottles from falling.

### **V30. V40 & V50 & V26 models**

When removing any of these shelves out of the rail compartment, tilt the shelf as per the diagram and simply pull out, or push in the shelf until it sits on the support brackets securely.

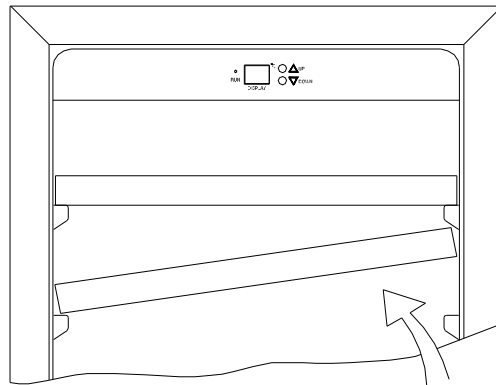

## **REVERSIBILITY OF THE DOOR**

**Warning:** To avoid accident during the process of changing the door, we recommend that you get assistance. Door is heavy and may cause injury if dropped.

According the model and the type of handle your wine cabinet is equipped with, such as long strait bar handle , the door might needs to be rotated for 180 degrees or changed for a right opening one.

## V30 models

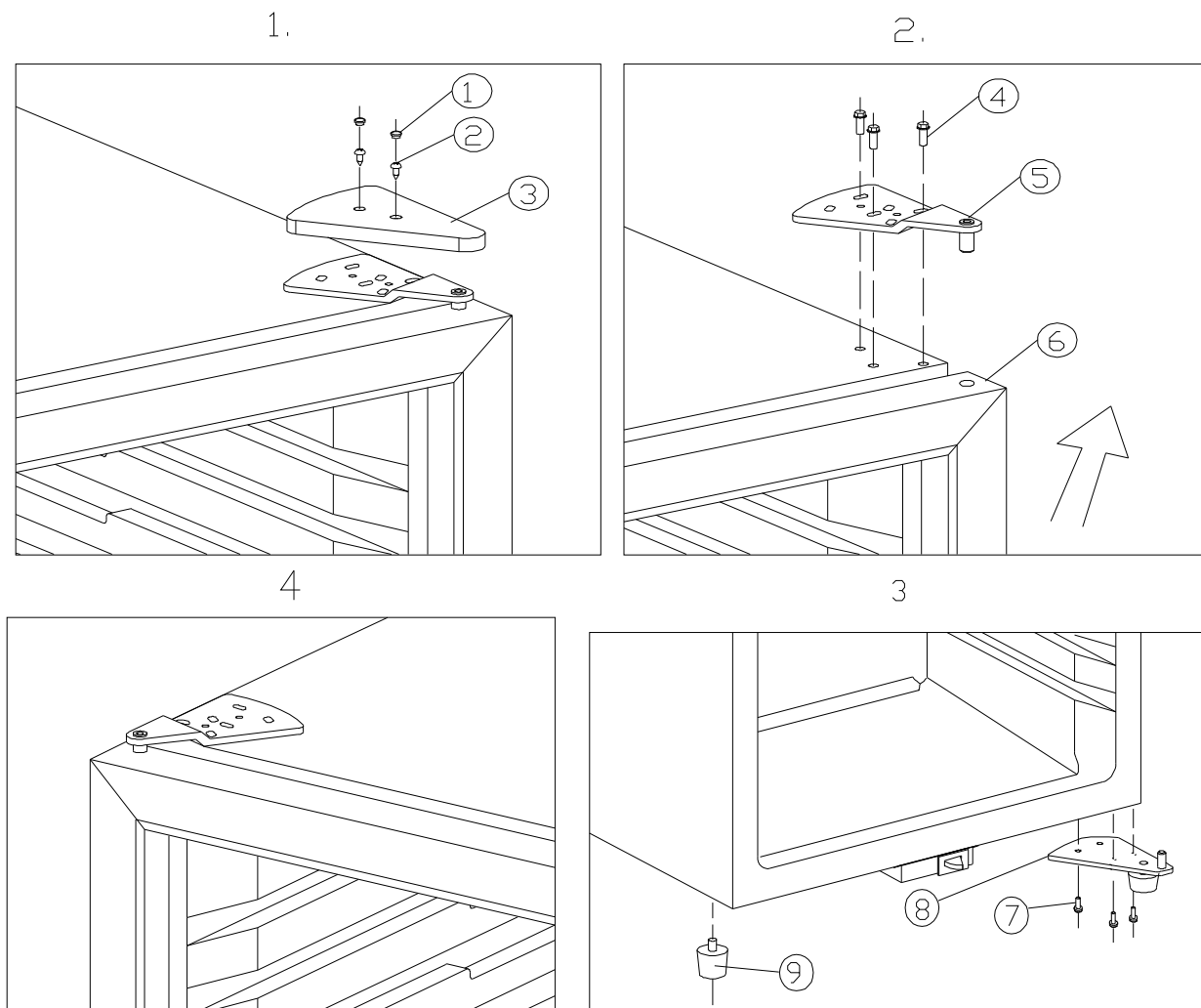

1 Rubber cover

2 Screw

3 Decorative cover

4 & 7 Screw

5 Top hinge module

6 Door

8 Lower hinge module-Left

9 Cabinet's leg-short

- Pull out the screw covers and unscrew the decorative cover. (Fig.1)
- **While holding the door firmly**, loosen and remove the top hinge, lift up and remove the door (See Fig.2)
- Unscrew the lower hinge (8).
- Remove the long cabinet leg (9) on the left side, and shift it to the right end side. (Fig. 3)
- Install the lower hinge and tie it with the bolts.
- Install the door on the axe of lower hinge (8) the same way it was removed, screw back the top hinge on the right
- Fix back the decorative cover and rubber cover.

## V40 models (30mm recess plinth)

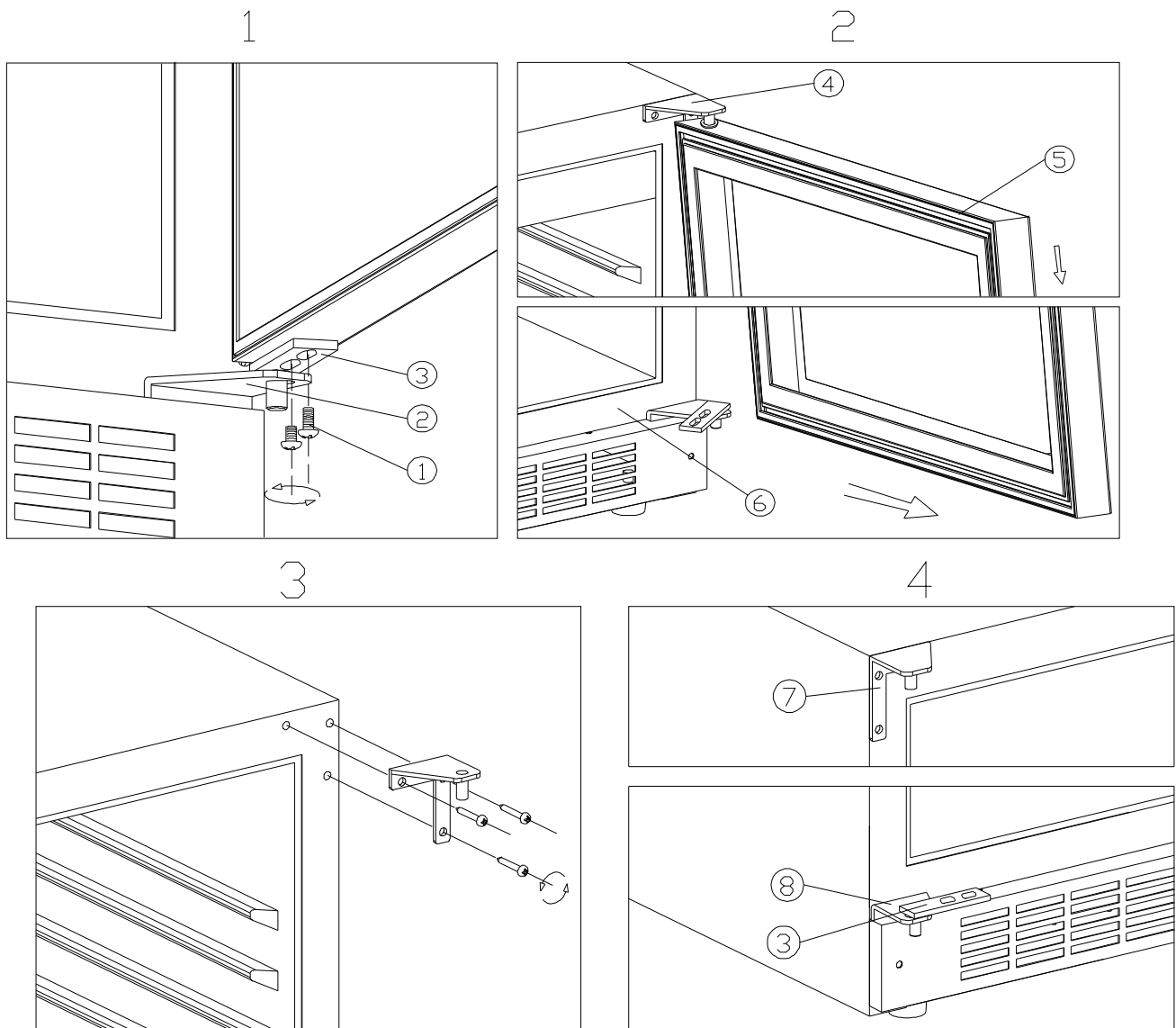

1 Lock screws

4 Top hinge (Right)

7 Top hinge (Left)

2 Lower hinge (Right)

5 Door

8 Lower hinge (Left)

3 Door axis

6 Cabinet body

- Unscrew the lock screws (1); (Fig. 1) to remove the door axis located at the bottom.
- **While holding the door firmly**, pull the door (5) outward and take it out; (Fig. 2)
- Remove the 3 bolts and take out the right top hinge (2); (Fig. 3)
- Fix the left top hinge and the bottom left hinge with the bolts as per Fig. 4,
- Re-install the door the same way it was removed and fix back the door axis.

## V40 models (85mm recess plinth)

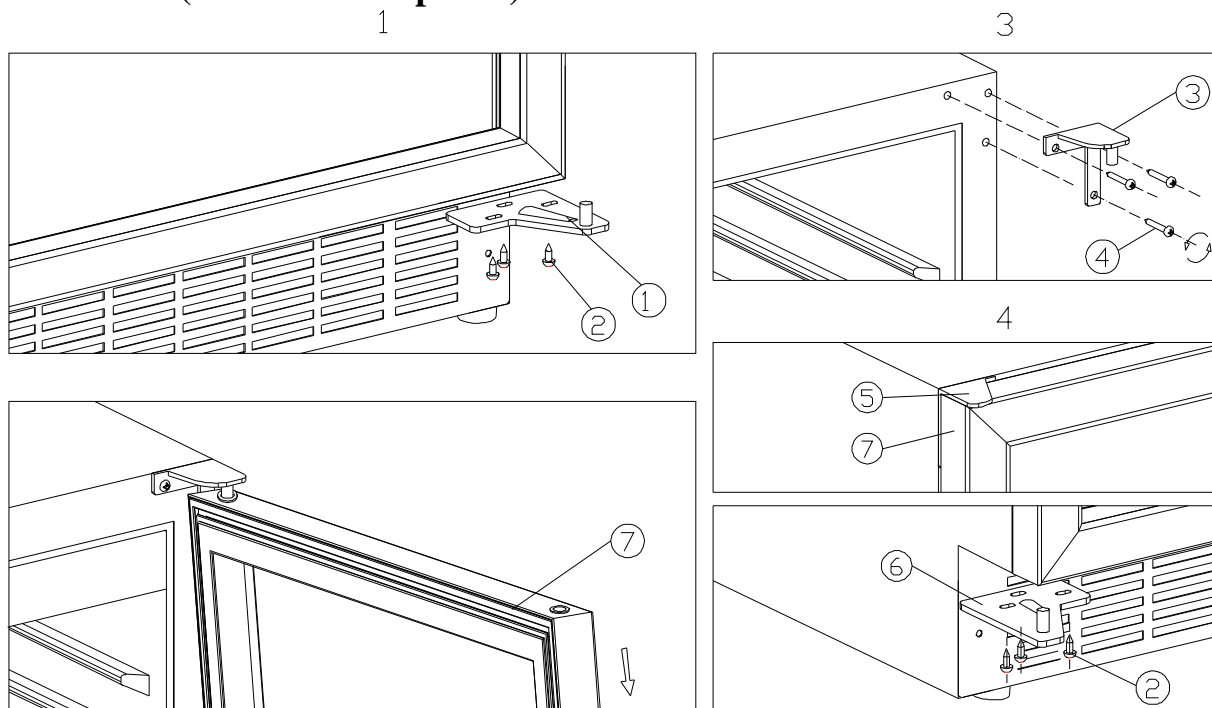

1 Lower hinge (Right)  
 4 Lock Screws  
 7 Door

2 Lock screws  
 5 Top hinge (Left)

3 Top hinge (Right)  
 6 Lower hinge (Left)

- **While holding the door firmly**, remove the three lock screws (2) from the lower right hinge module, and remove it. (Fig.1)
- Remove the three lock screws (4) from the top right hinge and remove the hinge (3). (Fig.3)
- Fix the top left hinge (5) at the top left corner with the three lock screws (4). (Fig.4)
- **While holding the door**, insert the axis core into the door's (7) upper left hinge's hole. Fix the left bottom hinges by inserting the axis core first into the door's lower left hinge's hole (6). Then tie the lower left hinge to finish the door replacement. (Fig. 5)

## V50/V26 models

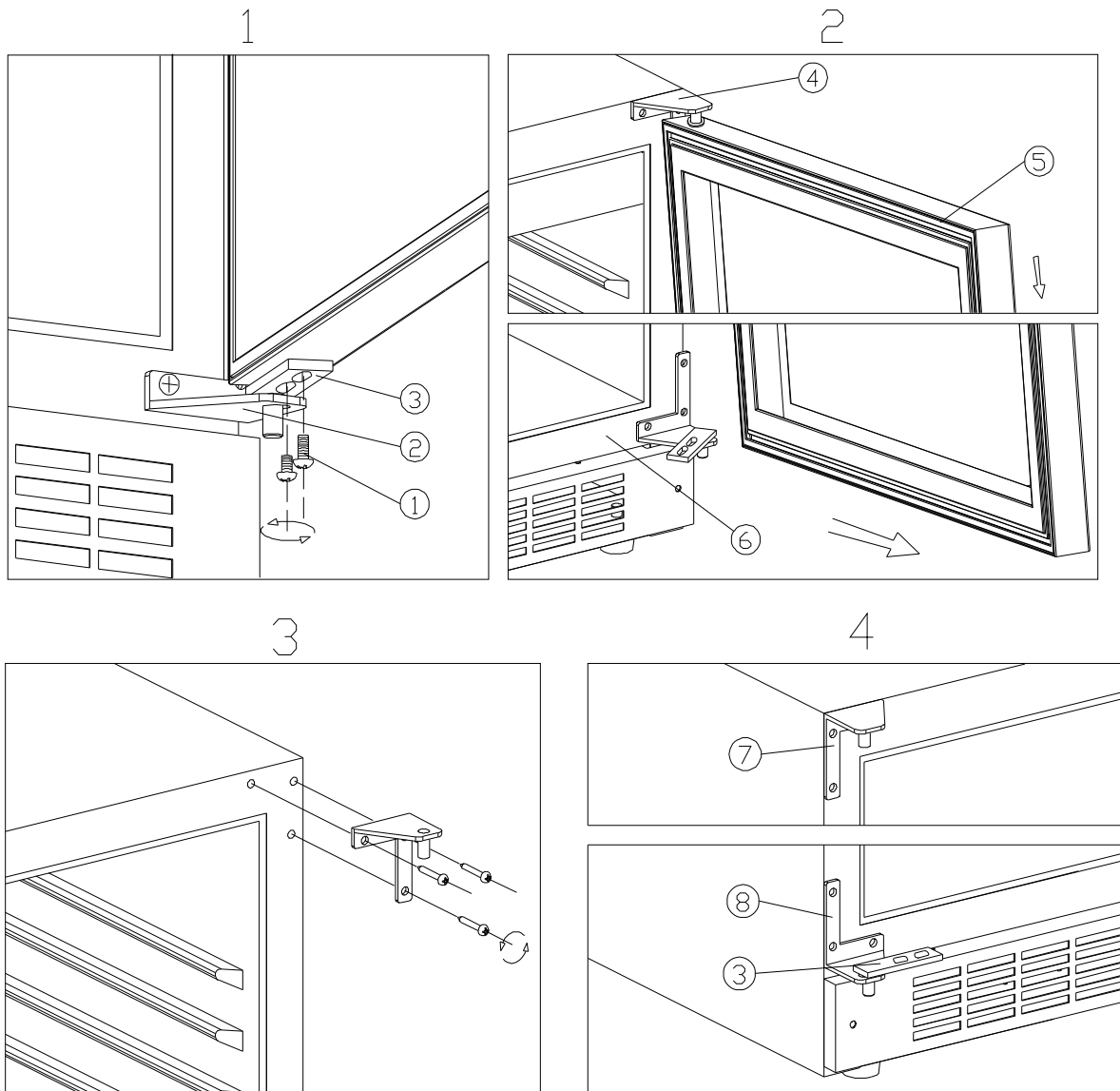

1 Lock screws

4 Top hinge (Right)

7 Top hinge (Left)

2 Lower hinge (Right)

5 Door

8 Lower hinge (Left)

3 Door axis

6 Cabinet body

- Remove the lock screws to untied the door axis at the bottom of the door (Fig 1)
- **While holding the door firmly**, pull the door (5) outward, take it out; (Fig. 2/4)
- Remove the Right Top hinge, (Fig 3).
- Install the left top hinge and left lower hinge , with bolts as per Fig. 4
- Put the door in position between the hinges and fix the door axes (3) onto the door.

## **OPERATION ANOMALIES**

Ensure that there is power to the electrical supply plug by connecting another electrical appliance to it. Check fuse, if any. Make sure that the door is closed properly.

If your wine cellar appears to be malfunctioning, unplug it and contact your **VINTEC's** after sales service. Any intervention on the cold circuit should be performed by a refrigeration technician who should carry out an inspection of the circuit sealing system. Similarly, any intervention on the electrical circuit should be performed by a qualified electrician.

**Notes :** *Any intervention performed by a non-technician will lead to the warranty being considered as null and void.*

## **POWER FAILURES**

In the event of a power interruption, all previous temperature settings are automatically erased and it will revert to a preset temperature setting . ( see preset chart)

Most power failures are corrected within a short period of time. An hour or two's loss of power will not affect your beverage center temperatures. To avoid sudden change of temperature while the power is off, you should avoid opening the door. For longer period of power failure, do take steps to protect your beverage.

**Irrespective of the cause, if you notice either abnormal temperature or humidity levels inside your wine cellar, be reassured that only long and frequent exposure to these abnormal conditions can cause a detrimental effect on your wines.**

### **TROUBLESHOOTING GUIDE**

Common problems may easily be solved, saving you the cost of a possible service call. Please read carefully the instruction manual and revert to troubleshooting guide chart.

<b>PROBLEM</b>	<b>POSSIBLE CAUSE</b>
Wine cellar does not operate.	Not plugged in. The appliance is turned off. The circuit breaker tripped or the fuse is broken.
Wine cellar is not cold enough.	Check the temperature control setting. External environment may require a higher setting. The door is opened too often. The door is not closed completely. The door gasket does not seal properly.
Turns on and off frequently.	The room temperature is hotter than normal. A large amount of contents has been added to the Wine cellar. The door is opened too often. The door is not closed completely. The temperature control is not set correctly. The door gasket does not seal properly.
The light does not work.	Not plugged in. The circuit breaker tripped or a blown fuse. The bulb is out of order. The light button is "OFF".
Vibrations.	Check to assure that the Wine cellar is level.
The Wine cellar seems to make too much noise.	The rattling noise may come from the flow of the refrigerant, which is normal. As each cycle ends, you may hear gurgling sounds caused by the flow of refrigerant in your Wine cellar. Contraction and expansion of the inside walls may cause popping and crackling noises. The Wine cellar is not level.
The door will not close properly.	The Wine cellar is not level. The door was reversed and not properly installed. The gasket is faulty. ( magnet or rubber is spoiled) The shelves are out of position.

## R134a:

Technical data	V30SG	V50SG	V30SGMe	V30SG''e'	V40SG''e''	V50SG''e''	V30SG''2e''	V40SG''2e''	V50SG''2e''	V50DG''2e''
Capacity750ml	35	50	35	35	40	50	Upper 10	Upper 16	Upper 14	Left 21
							Lower 20	Lower 22	Lower 34	Right 21
Gas charge quantity in grams	50 g	50 g	45g	45 g	50 g	50 g	45 g	50 g	50 g	70 g
Net capacity	123L	161L	123L	122L	150L	161L	114L	140L	151L	145L
Pre-set temp in degrees	Normal	Normal					upper 6	upper 6	upper 6	Right 12
	(10-14)	(10-14)	12	12	12	12	Lower 12	Lower 12	Lower 12	Left 7
Adjustable temp in degrees	5 to 18	5 to 18	5 to 18	3 to 18	5 to 18	5 to 18	upper 5-10	Upper 5-10	Upper 5-10	Right 5-18
							Lower 10-18	Lower 10-18	Lower 10-18	Left 5-18
Power Input	140W	140W	120W	120W	140W	140W	120W	140W	140W	120W
Heater <sup>(0)</sup>	--	--	--	--	--	--	Yes	Yes	Yes	Yes
Freestanding or Built-in	Freestanding	Built-in	Freestanding	Freestanding	Built-in	Built-in	Freestanding	Built-in	Built-in	Built-in
N°. of wooden shelf: <sup>(1)</sup>	4 (max 6)	4 (max 7)	4 (max 6)	4 (max 6)	5	4 (max 7)	4 (max 5)	4 (max5)	4 (max 6)	14
Ambient temp in degrees	5-35°C	5-35°C	5-35°C	5-35°C	5-35°C	5-35°C	0-35°C	0-35°C	0-35°C	5-35°C
Net dim in mm WDXH	493x588x840	605x605x875	493x588x840	493x588x840	595x572x820	605x605X875	493x588x840	595x572x820	605x605X875	605*602*875
Gross dim in mm WDXH <sup>(2)</sup>	550x650x880	680x725x935	550x650x880	550x650x880	655x665x875	680x725x935	550x650x880	655x665x875	680x725x935	675*685*910
Net weight	38 kg	52 kg	38 kg	38 kg	44 kg	52 kg	43 kg	50 kg	55 kg	59 kg
Gross weight	42 kg	56 kg	42 kg	42 kg	48 kg	56 kg	47 kg	54 kg	59 kg	63 kg

<sup>(0)</sup> Units with no heater will not raise its internal temperature if the ambient temperature where the unit is located is lower than the set temperature.

<sup>(1)</sup> Subject to changes accordingly to various references and models modifications.

<sup>(2)</sup> Based on carton box packing dimensions/weight

<b>Standard features:</b>
Compressor operated: R134a
- Available in rated voltage/frequency (as per country's requirements): 100V/50/60Hz, 220V/50/60Hz,115V/50Hz
- Automatic defrost
- Humidity: 65% RH +/-10% RH
- Black outer and inner finish
- Internal light
- Adjustable feet x 4
- Double glass door with 3rd acrylic layer
- Stainless steel finish door frame for "ss" models



## R600a:

Technical data	V40SD"2e"	V26SG"e"	AL-V30SG"e"	AL-V40SG"e"	AL-V30SG"2e"	AL-V40SG"2e"	AL-V40DG"2e"
Capacity 750ml Bottles	Upper 16	26	35	40	Upper 10	Upper 16	Left 19
	Lower 22				Lower 20	Lower 22	Right 19
Gas charge quantity	35g	30g	30g	35g	30g	35g	45g
Net capacity	140L	81.2L	123L	150L	114L	140L	135L
Pre-set temp in degrees	upper 6	12	12	12	upper 6	upper 6	Right 12
	Lower 12				Lower 12	Lower 12	Left 7
Adjustable temp in degrees	Upper 5-10	5 to 18	3 to 18	5 to 18	upper 5-10	Upper 5-10	Right 5-18
	Lower 10-18				Lower 10-18	Lower 10-18	Left 5-18
Power Input	100W	90W	87W	100W	87W	100W	107W
Heater <sup>(0)</sup>	Yes	--	--	--	Yes	Yes	Yes
Freestanding or Built-in	Built-in	Built-in	Freestanding	Built-in	Freestanding	Built-in	Built-in
N°. of wooden shelf: <sup>(1)</sup>	4(max5)	5	4 (max 6)	5	4 (max 5)	4(max5)	12
Ambient temp in degrees	0-35°C	5-35°C	5-35°C	5-35°C	0-35°C	0-35°C	5-35°C
Net dim in mm WDXH	595x572x820	380x550x805	493x588x840	595x572x820	493x588x840	595x572x820	595*573*820
Gross dim in mm WDXH <sup>(2)</sup>	655x665x875	415x625x845	550x650x880	655x665x875	550x650x880	655x665x875	655x665x875
Net weight	48 kg	34kg	38 kg	44 kg	43 kg	50 kg	50 kg
Gross weight	52kg	38kg	42 kg	48 kg	47 kg	54 kg	54 kg

<sup>(0)</sup> Units with no heater will not raise its internal temperature if the ambient temperature where the unit is located is lower than the set temperature.

<sup>(1)</sup> Subject to changes accordingly to the various references and models modifications.

<sup>(2)</sup> Based on carton box packing dimensions/weight

<b>Standard features:</b>
Compressor operated: R600a
- Available in rated voltage/frequency (as per country' requirements): 100V/50/60Hz, 220V/50/60Hz, 115V/50Hz
- Automatic defrost
- Humidity : 65% RH +/-10% RH
- Black outer and inner finish
- Internal light
- Adjustable feet x 4
- Double glass door with 3rd acrylic layer
- Stainless steel finish door frame for "ss" models



Copyright: All rights are reserved. All photocopying, reproduction, translation whether partial or total are strictly prohibited, without prior written consent from **VINTEC**.

**[www.vintec-cellar.com](http://www.vintec-cellar.com)**

